



Student application number

S	2	1	0						
---	---	---	---	--	--	--	--	--	--

Given name(s)

Family name

Selective High School Placement Test

Reading Question Paper

Sample Test

40 minutes

INSTRUCTIONS TO CANDIDATES

Please read this page carefully.

DO NOT OPEN THIS QUESTION PAPER UNTIL YOU ARE TOLD TO DO SO.

A separate answer sheet is provided for this test. Please fill in the following information on your answer sheet:

- Student application number
- Given name(s)
- Family name

There are **30** multiple-choice questions in this paper. For each question, choose the **one** correct answer and record your choice on the separate answer sheet. If you make a mistake, erase thoroughly and try again.

You will **not** lose marks for incorrect answers, so you should attempt **all 30** questions.

You must complete the answer sheet within the time limit. There will **not** be any extra time at the end of the exam to record your answers on the answer sheet.

You can use the question paper for notes, but no extra paper is allowed.

Please note that some words and phrases are **shaded** in the texts as they are referred to in some questions.

Dictionaries and calculators may **NOT** be used.



PV7

BLANK PAGE

Read the extracts below then answer the questions.

Extract A: from *Picnic at Hanging Rock* by Joan Lindsay

They were off; the College already out of sight except for the tower through the trees as they bowled along the level Melbourne-Bendigo road, vibrating with particles of fine red dust. 'Get up Sailor, you lazy brute ... Prince, Belmonte, get back in your collars ...' For the first mile or two, the scenery was familiar through the girls' daily perambulation in crocodile formation. The passengers knew only too well, without bothering to look out, how the scraggy stringy bark forest lined the road on either side, now and then opening out onto a lighter patch of cleared land. The Comptons' whitewashed cottage whose sprawling quince trees supplied the College with jellies and jams, **the clump of wayside willows** at which the governess in charge would invariably call a halt and head for home. It was the same in Longman's Highroads of History, where the class were forever turning back for recapitulation at the death of King George the Fourth before starting off again with Edward the Third next term ... Now the willows in rich summer green were gaily passed and a sense of adventure ahead took over as heads began to peer through the buttoned tarpaulin flaps of the horse-drawn coach.

At Mrs Appleyard's college SILENCE WAS GOLDEN, written up in the corridors and often imposed. There was a delicious freedom about the swift steady motion of the coach and even in the warm dusty air blowing up in their faces that set the passengers chirping and chattering like budgerigars.

The road to Hanging Rock turns sharply away to the right a little way out of the township of Woodend. Here Mr Hussey pulled up outside the leading hotel to rest and water his horses before starting on the last lap of the drive. Already the heat inside the vehicle was oppressive and there was a wholesale peeling off of the obligatory gloves. 'Can't we take our hats off too, Mam'selle?' asked Irma whose ink-black curls were flowing out in a warm tide under the brim of her stiff school sailor. Mademoiselle smiled and looked across at Miss McCraw, sitting opposite, awake and vertical, but with two closed eyes, two puce kid hands locked together on her lap. 'Certainly not. Because we are on an excursion, there is no necessity to look like a wagon load of street urchins.'

The rhythmic beat of the horses' hooves combined with the close air of the coach was making them all sleepy. As it was still only eleven o'clock, with plenty of time in which to reach the picnic grounds for lunch, the governesses conferred and Mr Hussey was requested to let down the steps of the coach at a suitable spot off the road. In the shade of an old white gum the zinc-lined wicker basket that kept the milk and lemonade deliciously cool was taken out and unpacked, **hats were removed without further comment** and biscuits handed round.

Extract B: from *The Family Law* by Benjamin Law

My family isn't the outdoors type. Despite being raised on the coast, Mum detested visits to the beach (all the sand it brought into the house), while Dad disapproved of wearing thongs ('It splits the toes'). We never camped. All those things involved in camping – pitching a tent; cooking on open fires; the insects; sleeping on rocks – they never appealed to us.

We preferred theme parks. For parents raising five children, theme parks made so much sense. They were clean and safe. There were clearly designated activities, and auditory and visual stimuli that transcended racial, language and age barriers. Also, you could buy heaps of useless souvenirs.

It was a family tradition that once a year, our family of seven (eight, including my grandmother) would cram ourselves into a 1990 grey five-seat automatic Honda.

Faces smashed against glass; no leg room; the two smallest children illegally wedged between various legs – we travelled like this for a good three hours before we reached the Gold Coast. We'd nod off at such extreme angles that our spines contorted. When we woke up, our shirts would be covered in drool we weren't even sure was ours. By the time we got to the theme park, our limbs were numb, our nerve endings destroyed.

On the day of the trip, we'd wake before sunrise in order to get there by opening time. Despite the three hours of pain we'd endured, we'd feel an overwhelming sense of wonder as the Thunderbolt, Dreamworld's rollercoaster, painted with flames, emerged from the trees that bordered the Pacific Highway. It would appear so suddenly, like a strange apparition or a mirage. We would crane our necks back, trying to take in the sheer majesty of it.

For questions 1 – 8, choose the option (A, B, C or D) which you think best answers the question.

- 1 Both extracts mention that during the trip, the passengers
- A were able to stop and have a snack.
 - B saw a spectacular landmark.
 - C experienced some discomfort.
 - D tried hard to stay awake.
- 2 Which group(s) of travellers passed the time by talking?
- A The College group
 - B The Law family
 - C Both
 - D Neither
- 3 In which extract(s) do the people dislike spending time in natural surroundings?
- A Extract A
 - B Extract B
 - C Both
 - D Neither
- 4 In Extract A, why is 'the clump of wayside willows' significant for the students?
- A It is the furthest point on their regular walks.
 - B They can buy homemade food there.
 - C It reminds them of a scene in their history book.
 - D They are allowed to go there alone.

- 5 In Extract A, who appears to be in charge on the excursion?
- A Mr Hussey
 - B Mademoiselle
 - C Miss McCraw
 - D Mrs Appleyard
- 6 In Extract A, what does the writer suggest by 'hats were removed without further comment'?
- A The governesses did not notice what had happened.
 - B The girls rarely had the chance to wear their hats.
 - C Wearing a hat was optional outside the College grounds.
 - D College standards were now being relaxed.
- 7 How does the writer in Extract B feel when the rollercoaster comes into view?
- A terrified
 - B relieved
 - C bewildered
 - D awestruck
- 8 From the first two paragraphs of Extract B we get the impression that
- A not every family member shared the parents' enthusiasm for theme parks.
 - B the writer is aware that others might find his family's love of theme parks puzzling.
 - C the writer regrets not experiencing camping trips when he was a child.
 - D theme parks are no longer as attractive to the writer as they used to be.

Read the poem below by Marianne Moore then answer the questions.

The Fish

wade

through black jade.

Of the crow-blue mussel-shells, one keeps
adjusting the ash-heaps;
opening and shutting itself like

an

injured fan.

The barnacles which encrust the side
of the wave, cannot hide
there for the submerged shafts of the

sun,

split like spun

glass, move themselves with spotlight swiftness
into the crevices—
in and out, illuminating

the

turquoise sea

of bodies. The water drives a wedge
of iron through the iron edge
of the cliff; whereupon the stars,

pink

rice-grains, ink-

bespattered jelly fish, crabs like green
lilies, and submarine
toadstools, slide each on the other.

All

external

marks of abuse are present on this
defiant edifice—
all the physical features of

ac-

cident—lack

of cornice, dynamite grooves, burns, and
hatchet strokes, these things stand
out on it; the chasm-side is

dead.

Repeated

evidence has proved that it can live
on what can not revive
its youth. The sea grows old in it.

For questions 9 – 14, choose the option (A, B, C or D) which you think best answers the question.

9 The title of this poem

- A prepares us for the important last line.
- B contrasts with the overall theme.
- C actually refers to a person.
- D leads us into the poem itself.

10 What is compared to 'an injured fan'?

- A the sea
- B an ash heap
- C a mussel
- D a bird

11 What lights up the water?

- A the spun glass
- B the sunlight
- C the starlight
- D a spotlight

12 In the way the writer uses the following words, which is the odd one out?

- A lilies
- B crabs
- C jellyfish
- D toadstools

13 The cliff has 'marks of abuse' caused by

- A exposure to wet, windy weather.
- B the movement of the sea.
- C animals and vegetation.
- D the actions of people.

14 What does the form of the poem as a whole reflect?

- A the scaly shape of a fish
- B the tiny movements of sea life
- C the movement of the waves
- D the destructive power of the sea

Read the text below then answer the questions.

Six sentences have been removed from the text. Choose from the sentences (A – G) the one which fits each gap (15 – 20). There is one extra sentence which you do not need to use.

Octopus farming

Plans to create octopus farms in coastal waters round the world have been denounced by an international group of researchers. They say the move is ethically inexcusable and environmentally dangerous, and have called on private companies, academic institutions and governments to block funding for these ventures.

The researchers say that farming octopuses would require the catching of vast amounts of fish and shellfish to feed them, putting further pressure on the planet's already threatened marine livestock. The group, led by Professor Jennifer Jacquet of New York University, argues that octopuses are highly developed and curious creatures. **15** 'We can see no reason why, in the 21st century, a sophisticated, complex animal should become the source of mass-produced food,' says Jacquet. "Octopuses eat fish and shellfish, and supplying enough to feed large numbers of them puts further pressure on the food chain. It is unsustainable. Octopus factory farming is ethically and ecologically unjustified."

There are about 300 species of octopus and many behave in surprisingly sophisticated ways. In tests, some have been shown to use tools, for example. **16** 'Once octopuses have solved a problem, they retain a long-term memory of the solution,' the researchers state in a paper in *Issues in Science and Technology*.

Octopuses are also a culinary delicacy. About 350,000 tonnes are caught every year and served in restaurants from Spain to Chile and from Mexico to Australia. However, numbers of octopus caught are reported to be in decline. **17** Wild-caught males and females are allowed to mate. Then their fertile eggs hatch out in containers and are grown into adults to be sold to markets round the globe.

18 This has made feeding them difficult and expensive. Keeping young animals in water whose salinity and temperature are carefully controlled has also proved tricky. These drawbacks have prevented octopus farms from making progress – until recently.

Aquaculturists have learned that the young of some octopus species are less fussy about the food they eat and have used these species as basic stock for breeding. **19** As a result, companies in Australia, Japan and Mexico have said they are hatching octopus

eggs in captivity and will soon be ready to sell farmed octopuses. **20** The main markets for the animals – the US, Europe, Japan and China – are areas where people are already well-fed. Octopuses are delicacies and do not deserve to be the focus of intensive farming. Peter Godfrey-Smith of Sydney University commented: ‘Why should research money be used to support a project that will inevitably have so many welfare and environmental problems once it is scaled up?’

- A** Fish farmers have turned to the rearing of octopuses to try to replace these dwindling catches.
- B** But might this actually be the best way to protect the species over the long term?
- C** Farming them intensively would probably cause large numbers of deaths from stress.
- D** There have also been advances in controlling the environments in which octopuses are raised.
- E** In one such experiment, scientists observed octopuses building shelters from pieces of coconut shell.
- F** But the case for octopus farming is weak, according to Jacquet and her co-authors.
- G** These efforts have foundered, however, because octopus larvae eat only live food.

Read the four extracts below on the theme of dreams.

For questions **21 – 30**, choose the option (**A, B, C** or **D**) which you think best answers the question.

Which extract...

describes a feeling of awareness of being in a dream? **21** _____

refers to using dreams as a source of professional inspiration? **22** _____

mentions being able to do something in a dream that would be impossible in real life? **23** _____

argues that dreams can teach us something useful? **24** _____

says that people mostly dream about everyday things? **25** _____

states that dreams usually lose their power once the person wakes up? **26** _____

mentions a place that looked different in a dream from its appearance in the writer's memory? **27** _____

describes how a strange occurrence prevented the writer from doing something? **28** _____

explains the reason we are willing to accept absurd things in our dreams as significant? **29** _____

discusses some advice about relaying dreams to others? **30** _____

Extract A

Last night I dreamt I went to Manderley again. It seemed to me I stood by the iron gate leading to the drive, and for a while I could not enter, for the way was barred to me. There was a padlock and chain upon the gate. I called in my dream to the lodge-keeper, and had no answer, and peering closer through the rusted spokes of the gate I saw that the lodge was uninhabited. Then, like all dreamers, I was possessed of a sudden with supernatural powers and passed like a spirit through the barrier before me. The drive wound away in front of me, twisting and turning as it had always done, but as I advanced I was aware that a change had come upon it; it was narrow and unkempt, not the drive that we had known. At first I was puzzled, and it was only when I bent my head to avoid the low swinging branch of a tree that I realized what had happened. Nature had come into her own again and, little by little, in her stealthy, insidious way had encroached upon the drive with long, tenacious fingers.

Extract B

Why do we feel the urge to talk about our dreams? We like to talk about dreams to help us prepare for how to act in dangerous situations in the future. Most of your dreams are going to seem pretty boring to most people. But if you're going to talk about some of your dreams, pick the ones in which you deal with a problem in some new way. This would make them more interesting than your happy dreams, and if you feel that you learned something about how to deal with a threat, maybe your audience will, too.

We tend to think of dreams as being really weird, but in truth, about 80 percent of dreams depict ordinary situations. We're just more likely to remember and talk about the strange or dangerous ones. Information we do not understand can often rouse our curiosity, particularly in the presence of strong emotion. The emotional pull of dreams makes even the strangest incongruities seem meaningful and worthy of discussion and interpretation.

Extract C

One morning, when I was younger, I gave a detailed description of my previous night's dream to my mother. When I finished, she said, "I'm going to tell you something. Don't ever share your dreams with anyone. It's boring to listen to other people's dreams." I was offended at first. But of course she was right; it's almost always deadly to hear other people talk about their dreams. As a rule, dreams die in the glare of the waking world, their shimmering aura evaporating in the harsh air outside the psyche. And yet, paradoxically, it's the emotional aura of dreams that makes them feel so urgently worth sharing in the first place.

I still share my dreams – just not verbally. Like so many other writers (and artists too) I employ dreams in my creative work. They're an engine, a lending library. It's a thrill to awake with a strange, arresting image in mind, or still grasping the thread of an allegorical dream story.

Extract D

For the first time in a long while, I had a dream which I feel like writing down. This was a dream where I was auditioning for an acting job, and the dream went lucid; I realized that what was going on was a dream. So, as I often do in these situations, I chilled out and tried not to actively do anything; I often like to just see what the dream reveals. A nondescript person came up to me and handed me a small white book with gold lettering. "Remember this book," said the person, "because when you wake up you're going to want to get a copy. Really remember it." I thanked them and looked at the book in my hand. There was a title and author's name written on it, but I couldn't interpret the text. I'd look at it, trying to remember what it said, then I'd look away, and when I looked back it said something completely different and I was unable to remember what I'd just read.

There's a great Batman episode all about this! Sometimes I can fully recall bits of dreamed text, but on waking after other dreams, it's all gone.

BLANK PAGE



Student application
number

S	2	1	0						
---	---	---	---	--	--	--	--	--	--

Given name(s)

Family name

Selective High School Placement Test

Mathematical Reasoning Question Paper

Sample Test

40 minutes

INSTRUCTIONS FOR CANDIDATES

Please read this page carefully.

DO NOT OPEN THIS QUESTION PAPER UNTIL YOU ARE TOLD TO DO SO.

A separate answer sheet is provided for this test. Please fill in the following information on your answer sheet:

- Student application number
- Given name(s)
- Family name

There are **35** questions in this paper. For each question there are five possible answers, **A, B, C, D** and **E**. Choose the **one** correct answer and record your choice on the separate answer sheet. If you make a mistake, erase thoroughly and try again.

You will **not** lose marks for incorrect answers, so you should attempt **all 35** questions.

You **must** complete the answer sheet within the time limit. There will **not** be any extra time at the end of the exam to record your answers on the answer sheet.

You can use the question paper for working out, but no extra paper is allowed.

Calculators and dictionaries are **NOT** allowed.



Cambridge Assessment
Admissions Testing

BLANK PAGE

1 Sandy's watch reads 1850.

What is the time one quarter of an hour later, in 12-hour format?

- A 6:35 am
- B 7:05 am
- C 6:35 pm
- D 6:45 pm
- E 7:05 pm

2 Jack divides a white wall into equal sections.

He paints some sections purple, as shown.

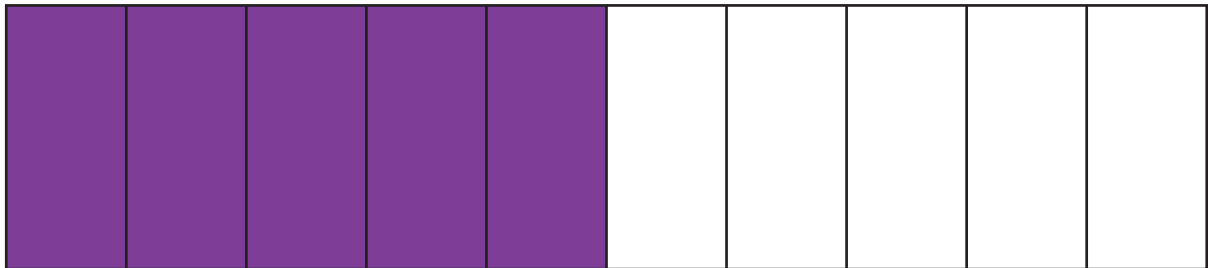

Jack then paints $\frac{2}{5}$ of the whole wall yellow.

Finally, he paints the rest of the wall green.

How many sections does he paint green?

- A 1
- B 2
- C 3
- D 4
- E 5

3 Nicola multiplies the smallest four-digit whole number by the largest two-digit whole number.

What is the answer?

- A 99 000
- B 99 990
- C 990 000
- D 999 900
- E 999 999

4 Rana needs 650 grams of cooking sauce.

She places a glass jar of cooking sauce on a scale.

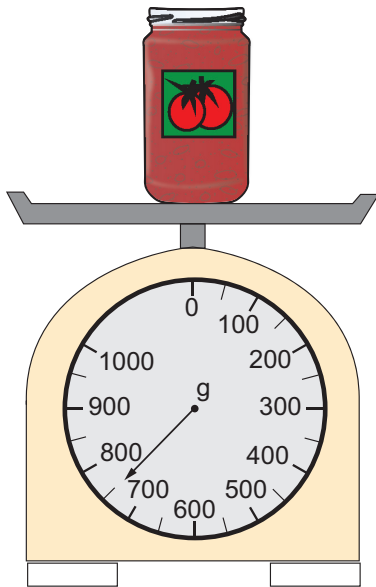

The glass jar weighs 330 g when empty.

How much more cooking sauce does Rana need?

- A 100 g
- B 130 g
- C 200 g
- D 230 g
- E 430 g

- 5 'Calculator numbers' are written in the style of digits on a calculator, as shown.



The calculator number eleven is the **smallest** two-digit number with **two** lines of symmetry.

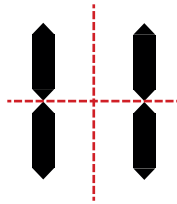

Which of the numbers below is the largest two-digit calculator number that has just one line of symmetry?

- A 52
 - B 83
 - C 88
 - D 96
 - E 99
- 6 Kim and Jamie each think of a different whole number that is greater than zero and less than 50.

Kim's number is a multiple of 5.

Jamie's number is an even number which is a multiple of 7.

What is the difference between the **largest** possible value of Kim's number and the **smallest** possible value of Jamie's number?

- A 31
- B 36
- C 38
- D 39
- E 43

7 Rectangles P and Q both have the same area.

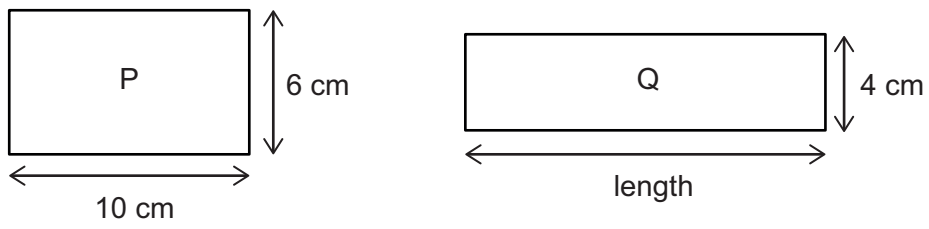

[diagram not to scale]

What is the length of rectangle Q?

- A 8 cm
- B 12 cm
- C 15 cm
- D 32 cm
- E 60 cm

- 8 Sooyoung has a glass containing 250 millilitres of cordial, and a bottle containing 1 litre of water.

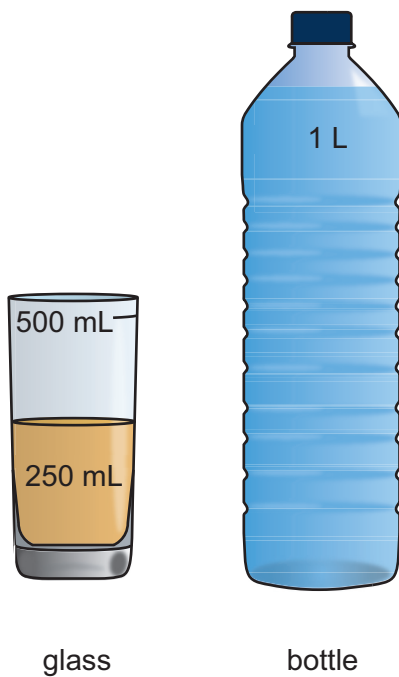

Sooyoung drinks 10 mL of the cordial.

She finds the drink too strong, so she pours water from the bottle into the glass until the water reaches the 500 mL mark.

How much water is left in the bottle?

- A 240 mL
- B 260 mL
- C 740 mL
- D 760 mL
- E 990 mL

9 \square always represents the same number.

\triangle represents a different number.

If

$$9 \times \square = 108$$

and

$$\triangle + \square = 36$$

what is \triangle ?

A 3

B 12

C 24

D 28

E 48

10



Tahnee is making a pattern out of white and black tiles.

She hasn't finished yet. She wants the finished pattern to have one vertical line of symmetry.

What is the smallest number of tiles she needs to add onto the right of the pattern?

A 2

B 3

C 6

D 8

E 9

11 Jessica has blue, green, red and yellow buttons in a bag.

There are twice as many red buttons as blue buttons.

If she takes one button out of the bag without looking:

- the probability that it is blue is 0.2
- the probability that it is green is 0.3

What is the probability that Jessica takes out a yellow button?

A 0.1

B 0.3

C 0.5

D 0.7

E 0.9

12 The graph shows the average monthly rainfall in Cairns for one year.

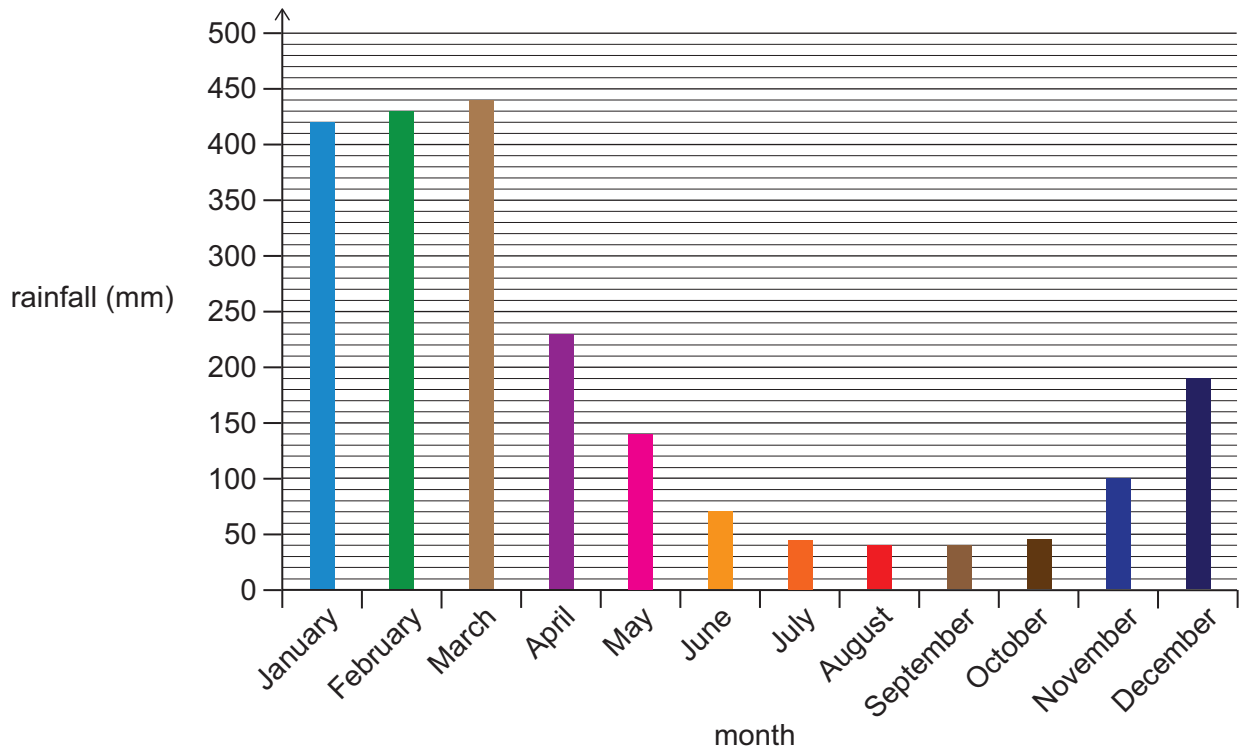

Here are three statements about the graph.

- 1 June had more than twice as much rainfall as August.
- 2 December had 9 cm more rainfall than November.
- 3 The rainfall in February, March and April combined was more than 1 metre.

Which of these statements are correct?

- A statement 1 only
- B statement 2 only
- C statements 1 and 2 only
- D statements 2 and 3 only
- E statements 1, 2 and 3

13 Alan had \$10. He gave some of this money to Kiana.

Alan then gave half of what he had left to Jason.

Jason gave half of what he was given to Lenny.

Lenny received \$1.60.

How much did Alan give to Kiana?

A \$3.20

B \$3.60

C \$4.80

D \$6.40

E \$6.80

14 Noah is drawing an accurate copy of this shape:

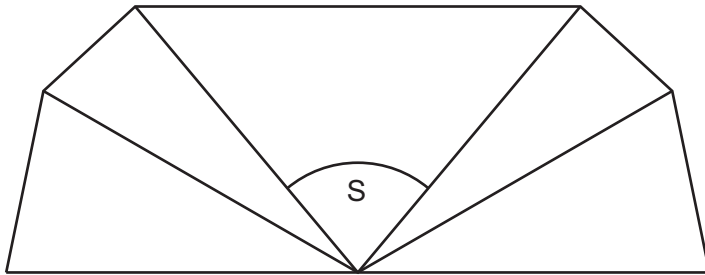

The shape has one line of symmetry.

He starts drawing the shape as follows:

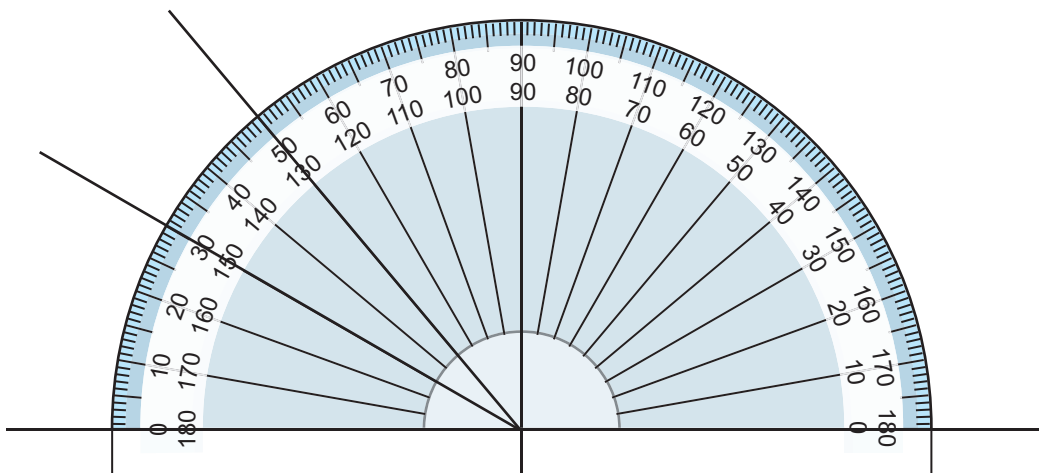

What is the size of angle S?

- A 50°
- B 80°
- C 90°
- D 100°
- E 130°

- 15 When 117 chocolates are shared between 14 people, each person gets 8 chocolates and there are 5 chocolates left over.

Which number sentence shows this information?

- A $14 + 8 \times 5 = 117$
- B $14 \times 5 - 8 = 117$
- C $14 \times 5 + 8 = 117$
- D $14 \times 8 - 5 = 117$
- E $14 \times 8 + 5 = 117$

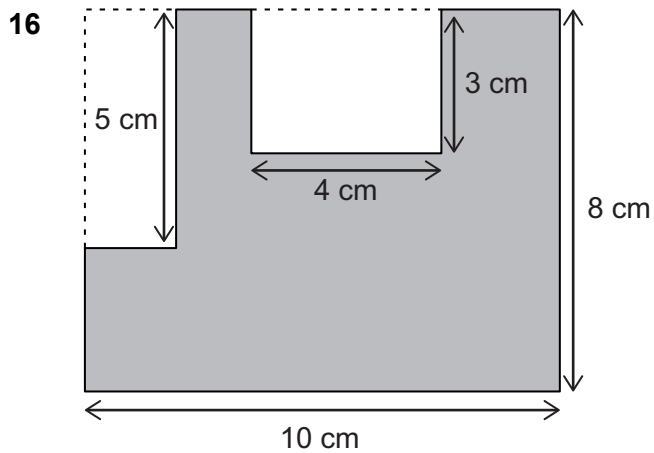

[diagram not to scale]

A large rectangle has sides 8 cm and 10 cm.

Two small rectangles are removed from this large rectangle.

This leaves the shaded shape.

What is the perimeter of the shaded shape?

- A 30 cm
- B 36 cm
- C 39 cm
- D 40 cm
- E 42 cm

17



Andy, Bella and Carlo shared a chocolate bar.

Andy ate $\frac{1}{5}$ of the bar, Bella ate $\frac{2}{5}$ of the bar and Carlo ate the rest.

Which of the following statements are correct?

- 1 Carlo ate less than half of the chocolate bar.
 - 2 Andy ate more than one quarter of the chocolate bar.
 - 3 Andy and Bella ate less than three quarters of the chocolate bar altogether.
-
- A statement 1 only
- B statement 2 only
- C statement 3 only
- D statements 1 and 2 only
- E statements 1 and 3 only

18 In a 'magic square', each row, each column and each diagonal add up to the same total.

In the magic square below, some of the numbers are missing.

20	15	16
18		◆

What is the missing number at ◆?

- A** 4
- B** 14
- C** 17
- D** 18
- E** 21

- 19 Chen has a spinner that is split into four equal sections.

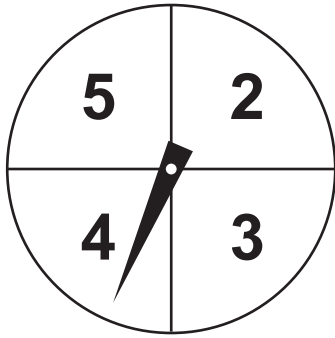

He spins the spinner and it lands on 4.

Now Emily is going to spin the spinner once. Which of these statements are correct?

- X** The probability of Emily getting a 4 is $\frac{1}{4}$
- Y** The probability that Emily's number is less than Chen's is $\frac{1}{2}$
- Z** The probability that Emily and Chen's scores add up to make more than 5 is $\frac{3}{4}$
- A** none of them
- B** statements X and Y only
- C** statements X and Z only
- D** statements Y and Z only
- E** statements X, Y and Z

- 20 There is something wrong with these scales. As shown, the pointer does not start at 0 kilograms when there is nothing on the scales:

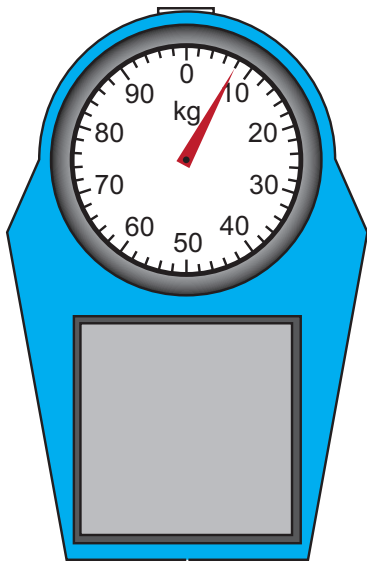

Apart from this, the scales work normally: the pointer goes up by 1 kg for every kilogram added to the scales.

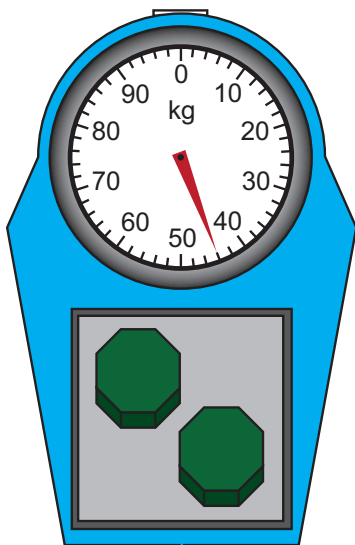

Two identical blocks are placed on the scales. The pointer makes less than a full turn.

What is the mass, in kg, of one of the blocks?

- A 13 kg
- B 14 kg
- C 18 kg
- D 19 kg
- E 22 kg

21 Alinta and Tau both round the number 4 850 000.

Alinta rounds the number to the nearest million.

Tau rounds the number to the nearest hundred thousand.

What is the difference between their answers?

A 0

B 50 000

C 100 000

D 150 000

E 200 000

22 Here is a graph showing the outdoor temperature during a period of 9 hours.

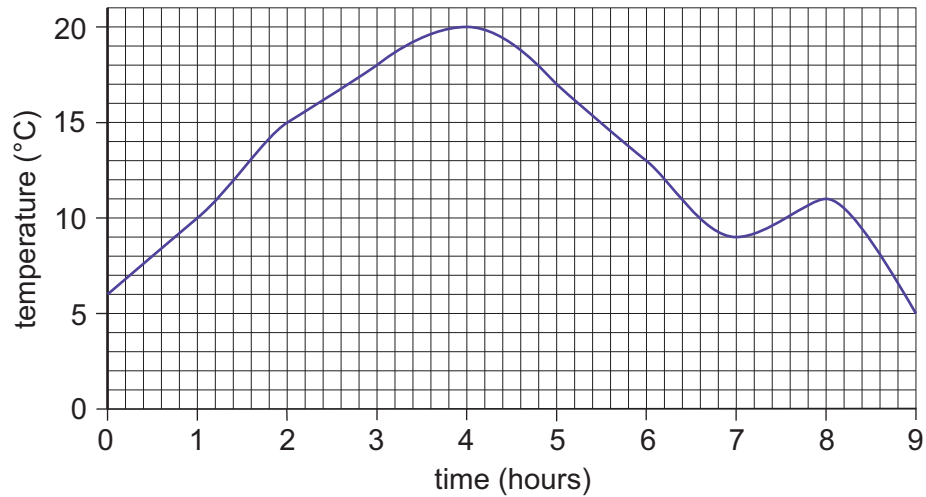

Which of these statements are true?

- 1 The temperature was 10°C at four different times.
 - 2 The temperature change between 1 hour and 3 hours was greater than the temperature change between 4 hours and 6 hours.
 - 3 The lowest temperature was 5°C .
- A** none of the statements
- B** statements 1 and 2 only
- C** statements 1 and 3 only
- D** statements 2 and 3 only
- E** statements 1, 2 and 3

23 Quoc bought 4 pizzas to share with Amina, Fred and Sally.

Amina ate $\frac{4}{5}$ of a pizza.

Fred ate $1\frac{1}{5}$ pizzas.

Sally ate $\frac{3}{5}$ of a pizza.

Quoc ate **all** of the pizza that was left.

How much **more** pizza did Quoc eat than Amina?

A $\frac{2}{5}$

B $\frac{3}{5}$

C $\frac{4}{5}$

D $1\frac{4}{5}$

E $2\frac{1}{5}$

24

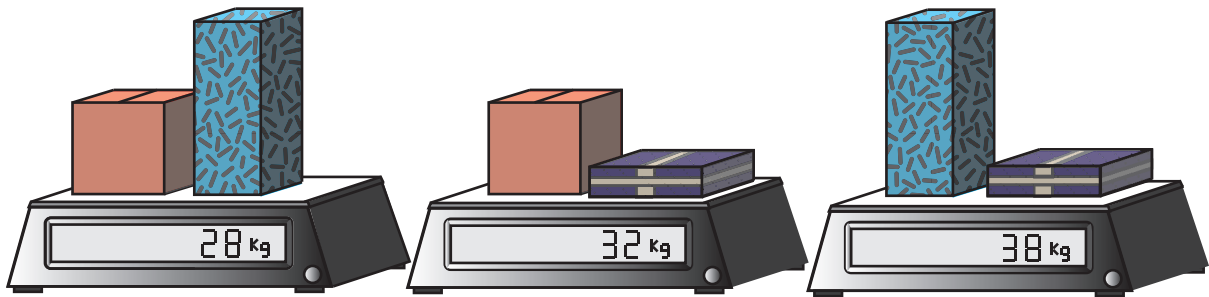

Three different boxes are weighed in pairs. Different pairs of boxes have combined weights of 28 kg, 32 kg and 38 kg as shown.

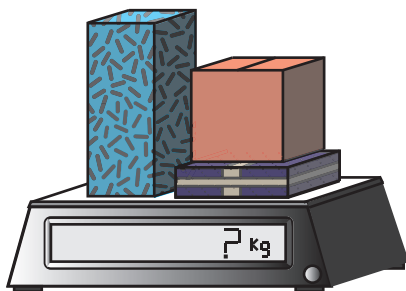

When the three boxes are weighed together, what is their combined weight?

- A 49 kg
- B 60 kg
- C 66 kg
- D 70 kg
- E 98 kg

25 What is the sum of the number of faces, the number of edges and the number of vertices of a pyramid with a hexagonal base?

- A 18
- B 20
- C 24
- D 26
- E 38

- 26** In our number system, the value represented by a digit depends on its position. For example, in the number 273, the digit 7 represents 70.

In the number 30 060, how many times larger is the value represented by the digit 3 than the value represented by the digit 6?

- A** 50 times
- B** 100 times
- C** 500 times
- D** 1000 times
- E** 2000 times

- 27** Kylie lives in Las Vegas and she visits her cousin Mike, who lives in Sydney.

Kylie leaves Las Vegas on Friday at 1300 local time on a 6-hour flight to New York.

She spends 24 hours in New York.

She then catches a 20-hour flight to Sydney.

The time in Las Vegas is 17 hours behind the time in Sydney.

What time is it in Sydney when Kylie arrives?

- A** Monday at 0800
- B** Wednesday at 1100
- C** Saturday at 2200
- D** Sunday at 1500
- E** Sunday at 2300

28 Here is a shape made of black and white parts:

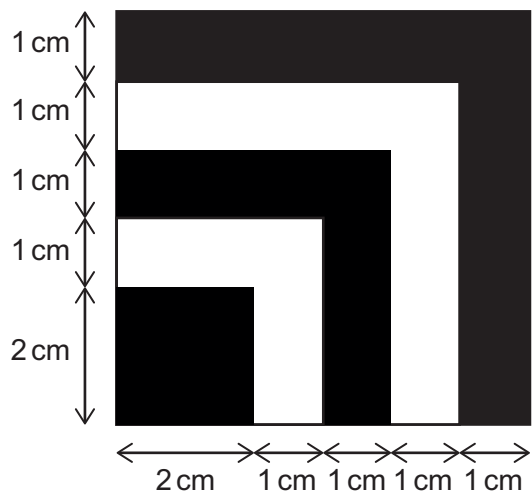

[diagram not to scale]

What is the total area that is black?

- A 14 cm²
- B 15 cm²
- C 20 cm²
- D 22 cm²
- E 24 cm²

29 Jan is making a mixed fruit drink for a party.

She puts some orange juice into the jug, as shown.

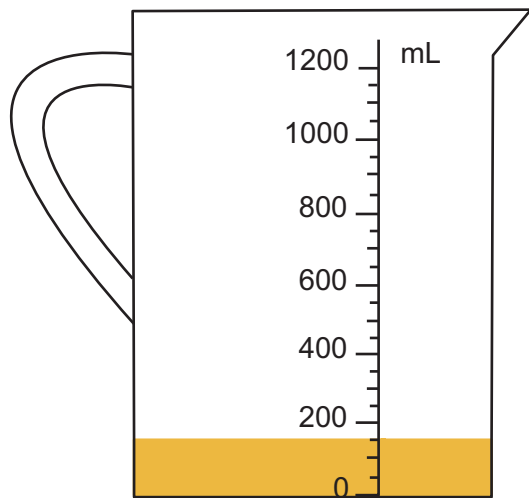

She then adds 6 times as much apple juice.

How many millilitres of fruit drink does Jan make?

- A** 400 mL
- B** 525 mL
- C** 900 mL
- D** 1050 mL
- E** 1500 mL

30

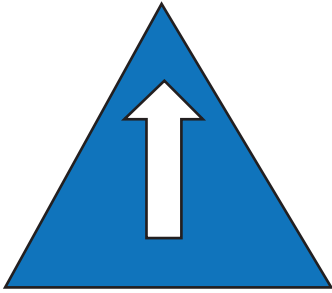

The equilateral triangle above is rotated anti-clockwise into the position shown below.

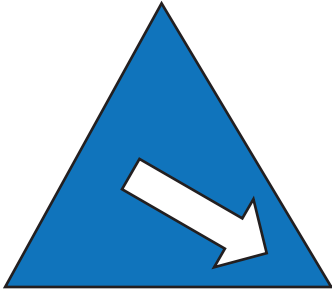

Through what angle is it rotated anti-clockwise?

- A 60°
- B 120°
- C 180°
- D 240°
- E 300°

- 31 Vinayak's little brother tried to draw three different nets of a cube, but he got it wrong. He only drew five squares for each net, but a complete cube net has six squares.

Here are his three drawings:

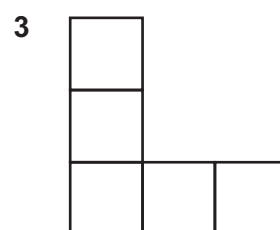
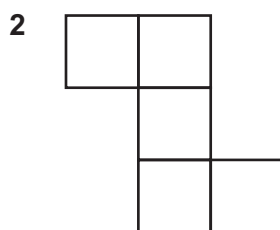

Vinayak wants to help, by adding **one more square** to each net to make a correct cube net. However, he is not sure if this is possible for all of the drawings.

Which of the three drawings can be made into complete cube nets by adding one square?

- A drawing 1 only
- B drawing 2 only
- C drawing 3 only
- D drawings 1 and 3 only
- E drawings 1, 2 and 3

32

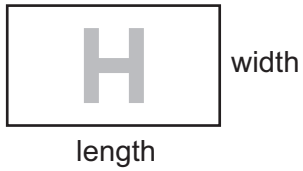

Harry is making shapes out of identical rectangular cards with the letter H on.

He makes shape X, then adds another card to make shape Y, as shown.

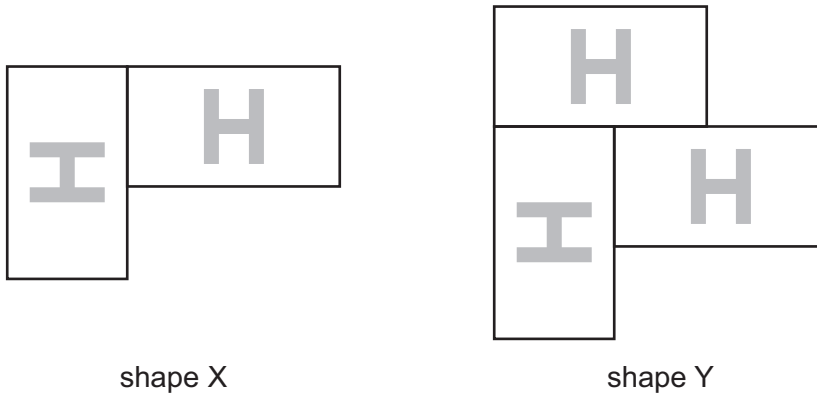

[diagrams not to scale]

The perimeter of shape X is 64 cm and the perimeter of shape Y is 82 cm.

What is the **width** of each of Harry's rectangles?

- A 3 cm
- B 4 cm
- C 5 cm
- D 8 cm
- E 9 cm

33 Claudia makes a number pattern using these rules:

- Choose the first three numbers.
- After this, each number is the sum of the three numbers before it.

Here is Claudia's pattern with three missing numbers labelled X, Y and Z.

2, X, 0, Y, 6, Z

All the numbers are whole numbers.

What number does Z represent?

- A** 8
- B** 9
- C** 10
- D** 11
- E** 12

34 In a game, I collect stars and hearts.

I get points when I collect a star. The number of points for a star is always the same.

I get a different number of points when I collect a heart. The number of points for a heart is always the same.

If I collect 3 stars and 5 hearts, I get 27 points.



If I collect 5 stars and 7 hearts, I get 41 points.



How many points do I get if I collect 1 star and 1 heart?



A 7

B 12

C 14

D 24

E 50

35 How many whole numbers between 1 and 100 are multiples of 3, but are not multiples of 8?

You should include 3 itself.

A 21

B 25

C 27

D 29

E 33

BLANK PAGE

BLANK PAGE

BLANK PAGE



Student application
number

S	2	1	0						
---	---	---	---	--	--	--	--	--	--

Given name(s)

Family name

Selective High School Placement Test

Thinking Skills Question Paper

SAMPLE TEST

40 minutes

INSTRUCTIONS FOR CANDIDATES

Please read this page carefully.

DO NOT OPEN THIS QUESTION PAPER UNTIL YOU ARE TOLD TO DO SO.

A separate answer sheet is provided for this test. Please fill in the following information on your answer sheet:

- Student application number
- Given name(s)
- Family name

There are **40** questions in this paper. For each question there are four possible answers, **A, B, C,** and **D**. Choose the **one** correct answer and record your choice on the separate answer sheet. If you make a mistake, erase thoroughly and try again.

You will **not** lose marks for incorrect answers, so you should attempt **all 40** questions.

You **must** complete the answer sheet within the time limit. There will **not** be any extra time at the end of the exam to record your answers on the answer sheet.

You can use the question paper for working out, but no extra paper is allowed.

Calculators and dictionaries are **NOT** allowed.



Cambridge Assessment
Admissions Testing

PV2

BLANK PAGE

1 Kai, Joe and Alice have 30 marbles each.

They take it in turns to roll a dice.

- If the number rolled is even, then that player has to give the number of marbles shown on the face of the dice to each of the other two players.
- If the number rolled is odd, then that player receives the number of marbles shown on the face of the dice from each of the other two players.

Kai rolls a 5.

Joe rolls a 2.

If the friends end up with 41, 20 and 29 marbles respectively, which number does Alice roll?

- A 1
- B 2
- C 3
- D 4

2 When Tom told Aida that he was thinking of giving up his hobby of drawing to focus on becoming an engineer, Aida said: "You don't need to give up a hobby like drawing just because you want to work in engineering. It's good for you to have hobbies. They help keep you happy and relaxed so you can also study harder."

Which one of these statements, if true, most **strengthens** Aida's argument?

- A Artistic or creative skills are seen as important skills for engineers to have.
- B Tom's latest school report said that he wasn't studying hard enough.
- C Tom's school encourages its students to have at least one hobby.
- D Learning to draw well also often takes hard work and concentration.

3 “Whoever stole the money must have had both an opportunity and a motive.”

If this is true, which one of these sentences must also be true?

- A** If Finn had both an opportunity and a motive, he must have stolen the money.
- B** If Finn did not steal the money, he cannot have had an opportunity.
- C** If Finn did not steal the money, he cannot have had a motive.
- D** If Finn did not have a motive, he cannot have stolen the money.

- 4 A digital display consists of seven segments which light up in different combinations to produce digits. For example, to display the digit '1' the two right-hand segments normally light up as shown:

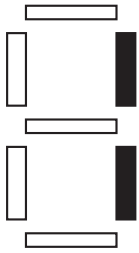

The display is used to show, in sequence, each of the digits 0 to 9. However, the display is faulty and two of the segments are not working. Two of the digits in the sequence are displayed as follows:

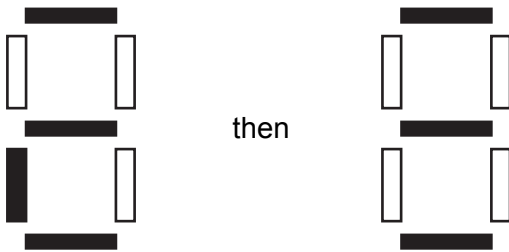

What is the next number in the sequence, as shown by the faulty display?

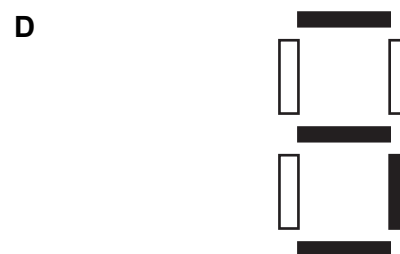
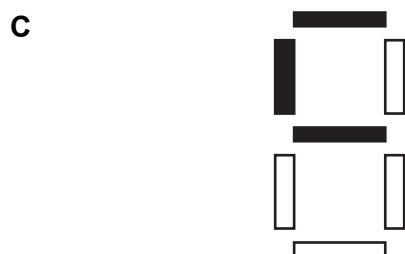
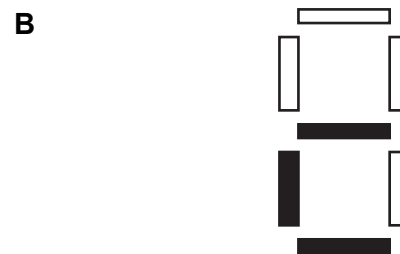
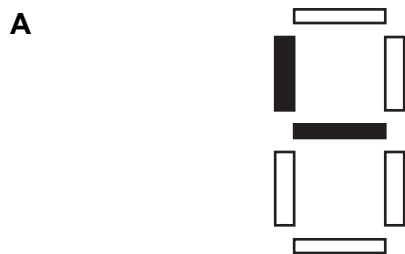

- 5 At the end of each term, Mr Chen gives scores in reading and writing to each student in his English class. These two scores are then added together to give an overall score in English for the term (for example, a student with scores of 30 in reading and 40 in writing would have an overall score of 70 in English).

Last term, Sara and Mila got the same overall score in English.



Sara: “If our scores in writing were different from each other, then our scores in reading must have been different too.”

Mila: “And if our scores in reading were the same, then our scores in writing must have been the same too.”

If the information in the box is true, whose reasoning is correct?

- A Sara only
 - B Mila only
 - C Both Sara and Mila
 - D Neither Sara nor Mila
- 6 The children Anita, Brian, Eric, Lee and Zara are all in one family. Lee is 1 year younger than Eric. Brian and Eric are twins. Anita is 3 years older than Lee. Brian is 8 years old. Zara is older than Eric, but younger than Anita.

Only one of the following sentences is true. Which is it?

- A Eric is 11.
- B Anita is 2 years older than Zara.
- C All the children are 8 or older.
- D Anita is 10.

7 A farmer has 245 female goats.
This year all but 9 of them have had kids.
None of them have had more than two kids.
357 kids have been born in total.
How many of the goats have had one kid only?

- A 115
- B 121
- C 124
- D 133

8 Sanjay said that wind farms will not meet all our energy needs as the demand for electricity grows, because we cannot rely on a source that varies with the weather. We need power 24 hours a day, 7 days a week, which is why the construction of wind turbines, with their uneven output, is not the solution.



Which one of these statements, if true, most **strengthens** Sanjay's argument?

- A Scientists have found that global average wind speeds are increasing.
- B There is no practical way to store the energy generated by wind turbines.
- C Local residents often complain about wind turbines spoiling the landscape.
- D A single wind turbine can generate the same energy as a thousand solar panels.

9

In the Junior Golf Championship, prizes are given out to the players who finish first, second, and third, and to anyone who gets a hole-in-one.



Sam: “Well, I know that one player scored a hole-in-one this year. So that means that four players will get prizes.”

Which one of the following sentences shows the mistake Sam has made?

- A** Some players might deserve a prize even if they didn’t score a hole-in-one.
- B** The hole-in-one might have been scored by a player who finished first, second, or third.
- C** Younger players might find it difficult to score a hole-in-one.
- D** We do not know the total number of players in the competition.

10 Shown below are the three small pieces of a puzzle.



Which one of the following big pieces can be combined with the three small pieces to make a square?

A

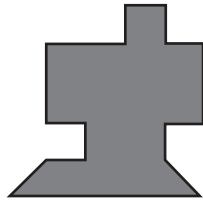

B

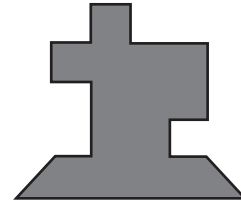

C

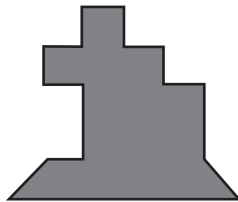

D

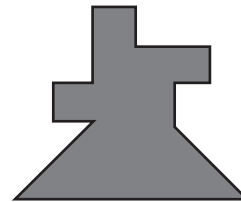

11

To become a successful architect, you need to be creative and also have excellent attention to detail.



Will: “Sally is creative – she loves drawing and painting – and always checks her written work carefully. She’s sure to become a great architect.”

Evie: “James enjoys writing stories and has a vivid imagination, but he struggles with detailed tasks. Architecture is probably not for him.”

If the information in the box is true, whose reasoning is correct?

- A Will only
- B Evie only
- C Both Will and Evie
- D Neither Will nor Evie

12

Five houses stand together in a row. One person lives in each house; each person likes a different sport; they all use different forms of transport. We also know that:

- Mr Green likes tennis and lives next to Ms White, who is on the left end of the row and drives a van.
- Dr Grey uses a taxi.
- The person who likes badminton lives in the middle of the row.
- Miss Orange drives a car and doesn’t like swimming.
- The person who likes swimming does not have a motorcycle.
- Mrs Black likes football; she lives next to Miss Orange and two houses from Dr Grey.
- The person who rides a bicycle also likes football.
- The person who likes golf lives next to the person who likes badminton.

Using the information above, who lives in the last house on the right of the row?

- A Dr Grey
- B Miss Orange
- C Mrs Black
- D Mr Green

- 13 Twelve students are studying Mathematics. They take three tests, each marked out of 100.

The results of the first two tests taken are shown below.

	<i>test 1</i>	<i>test 2</i>
Tom	48	53
James	83	86
Alira	61	67
Connor	73	54
Edward	66	59
Heidi	69	78
Jo	33	98
Kai	88	44
Sarah	100	53
Piper	75	78
Layla	81	79
Isabelle	57	65

A prize is awarded to the student with the highest combined total score from the three tests. If two students are tied for the highest score, nobody gets the prize.

As the scores currently stand, one student is able to be sure to win this prize as long as a high enough score is achieved in the final test.

What is the minimum score in the final test that will guarantee this student the prize?

- A 92
- B 94
- C 96
- D 98

- 14 Anh's mother has written a letter to the school. She has suggested that, for the children's safety, cars should be banned from the roads around the school at the beginning and end of the day, as there is a high risk of a child being involved in an accident.

Which one of these statements, if true, most **strengthens** Anh's mother's argument?

- A Parents who go to work after taking children to school may be late if they have to walk with their children to school.
- B When people cannot find a place to park they can get very bad-tempered.
- C Exhaust fumes from cars are invisible but very harmful to children.
- D People who live close to the school have complained about the noise at the beginning and end of the school day.

15

Ferdinand has an atlas which he can use to look up any city in the world.



Ferdinand: “If you tell me the name of a city, you don’t need to tell me which country it’s in – I can look it up in my atlas.”

Which one of the following sentences shows the mistake Ferdinand has made?

- A There are some cities which have the same name as the country they are in.
- B There are some cities which have the same name as each other.
- C There are some countries which do not have any cities at all.
- D There are some cities that have changed their name.

- 16 I have used 4 identical tiles to make a pattern on the floor. There is a grey rectangle on top of the tiles so that only part of the pattern is visible.



Using the same orientation as the diagram above, what is the pattern that is covered by the grey rectangle?



- 17 Jun's school was selecting students for a new course in computer programming. As well as considering their existing knowledge of computer programming, the school set them a maths test and a chess challenge.

If a student had at least some existing knowledge of programming, then they only had to pass the maths test. If they had none, then they either needed to get an excellent score on the maths test, or do well in both the maths test and the chess challenge.

Jun is an experienced computer programmer but failed to get a place on the course. What must have been the reason?

- A He did badly in the chess challenge.
- B He did not get an excellent score in maths.
- C He failed his maths test.
- D He did badly in both maths and chess.

- 18 Monotremes are the only type of mammal that lay eggs.



Jack: “If you see a mammal laying an egg, you know it must be a monotreme.”

Amelia: “And if you see an animal laying an egg, and you know it isn’t a monotreme, then it can’t be a mammal.”

If the information in the box is true, whose reasoning is correct?

- A Jack only
 - B Amelia only
 - C Both Jack and Amelia
 - D Neither Jack nor Amelia
- 19 The prices for passes for a tourist bus are shown in the table below.

<i>pass for 1 day</i>	<i>pass for 4 consecutive days</i>	<i>pass for 7 consecutive days</i>
\$5	\$10	\$20

I will need a pass on the following days of the month: 2, 3, 4, 6, 10, 11, 12, 14, 15, 16.

How much is the cheapest valid combination I could use?

- A \$30
- B \$35
- C \$40
- D \$45

- 20** There are some countries in the world where a high birth rate is a major worry, especially when the country is less economically developed, and resources to feed and care for children are scarce. But in other countries, the opposite is the case. The birth rate in several rich countries is falling, at the same time as older people there are living longer. This will become a problem as time goes on, because there will be far more old people who need looking after, but far fewer younger people to do that. By allowing birth rates to fall so much, these countries are storing up a problem for the future.

Which of these statements, if true, most **strengthens** the above argument?

- A** Parents who have fewer children can devote more time and energy to the children they do have.
- B** Older people have much greater health needs, especially when they are over 85.
- C** Older people do not always want to be dependent on their children and grandchildren.
- D** Young people should see care of their parents and grandparents as their duty.

- 21** If Monti does not sleep well, then he's likely to be tired.

If he is tired, then he will not perform well at the interview.

If he performs well at the interview, then he might be offered the job. Otherwise he doesn't stand a chance.

If the above statements are correct, which one of the following is **not** possible?

- A** Monti did not sleep well but got the job.
- B** Monti slept well but did not get the job.
- C** Monti performed well at interview but did not get offered the job.
- D** Monti was tired at the interview but still did well enough to get the job.

22 When viewed from above, an object looks like the picture shown below:

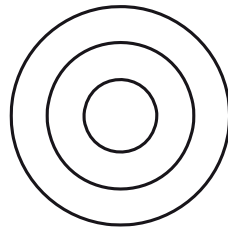

Which one of the following is a possible view from the side?

A

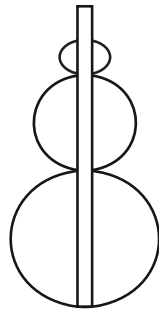

B

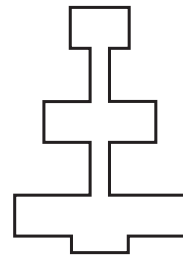

C

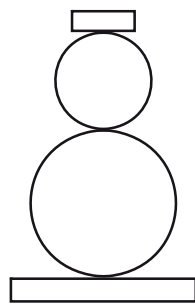

D

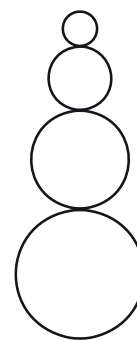

23

Jarrah's music teacher has promised that any students who did not have a chance to perform in the Spring concert will definitely be chosen to play in the Autumn concert.



Jarrah: "Well, I did perform in the Spring concert. So that means I definitely won't be chosen for Autumn. I'll have to find something else to do."

Which one of the following sentences shows the mistake Jarrah has made?

- A Just because anyone who did not play in Spring will play in Autumn, it does not mean that anyone who played in Spring will not play in Autumn.
- B Just because somebody is chosen for the concert, it does not mean they will actually perform.
- C Just because Jarrah was chosen to perform at a concert in the past, it does not mean he will be chosen again in future.
- D Just because someone did not perform in the Spring concert, it does not mean that they would not have liked to.

24

In a survey of television viewers, everyone who liked volleyball liked skiing. Everyone who liked skiing liked cycling, but no one who liked skiing liked gymnastics.

Darren, Amanda, Lee and Jess all took part in the survey.

Based on the above information, which one of the following must be true?

- A If Darren likes cycling, he also likes skiing.
- B If Amanda does not like gymnastics, she does not like cycling.
- C If Lee does not like volleyball, he does not like skiing.
- D If Jess likes volleyball, she does not like gymnastics.

- 25 A band is performing at the local park. The first performance will be on Saturday 1st August and the final performance will be on 31st August. There will be two performances on every Monday and every Tuesday, no performances on 22nd August and 23rd August, and one performance on each of the other days.

How many performances will there be altogether?

- A 38
- B 39
- C 40
- D 41

- 26 Why is it that Brazil has produced such successful soccer teams, and so many brilliant players? One theory is that it is because Brazil has a lot of very poor areas, and so people are just desperate to leave the 'favelas' (slums), and that becoming a professional soccer player is a good way to do this. But a better explanation is the unique popularity in Brazil of a game called futsal. Futsal is played with a smaller ball that is more difficult to control, and in smaller spaces where people have to think faster and be more accurate with their passing. As former soccer superstar Ronaldinho said, "When you come to play soccer, it's easy if you've come from futsal."

Which one of the following, if true, most **strengthens** the above argument?

- A Ronaldinho played futsal extensively before turning to soccer.
- B Ronaldinho is not the only successful soccer player from Brazil to have started by playing futsal.
- C Some coaches in other countries also believe that futsal is the best way to improve soccer skills.
- D There are many other countries that have areas as poor as Brazil that have not had the same success in soccer.

27

Whenever the red light on the side of Yifan's computer is flashing on and off, it means that the processor is starting to overheat.



Yifan: “The red light isn’t flashing at the moment, so the temperature of the processor must be fine.”

Ria: “No, that’s not right. The light is on continuously – that must mean that the processor has already overheated!”

If the information in the box is true, whose reasoning is correct?

- A Yifan only
- B Ria only
- C Both Yifan and Ria
- D Neither Yifan nor Ria

28 Earlier today I spilt some ink onto the carpet of my living room, and I have had no success trying to remove the stain.

This is how the carpet looks at present:

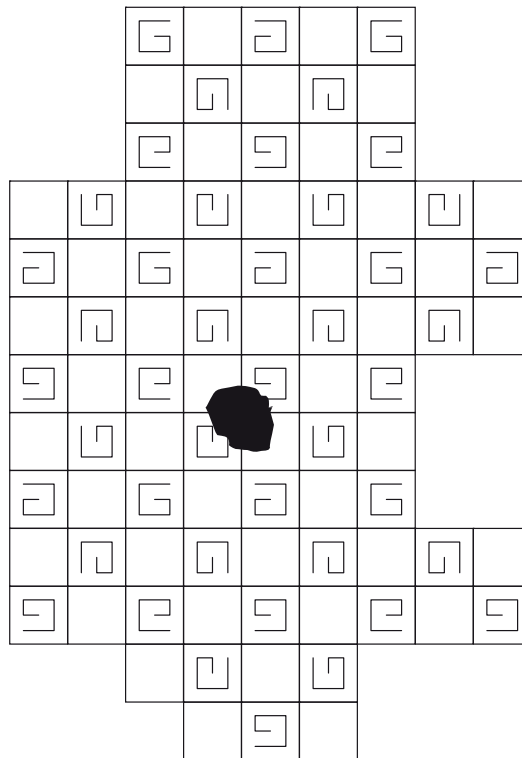

Fortunately I have some offcuts from when the carpet was laid, and I have discovered that if I carefully cut out an appropriately sized piece of the carpet around the stain, one of the offcuts will fit into the space exactly without disrupting the pattern.

Which one of my offcuts can I use to replace the stained piece?

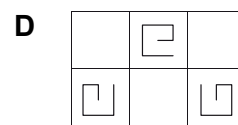
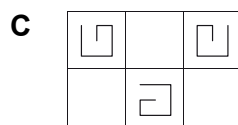
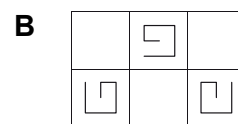
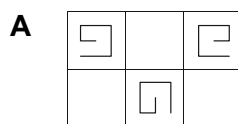

29 Five children did a test with five difficult questions to answer.

- Hailey was faster than Gabriella, but got three questions wrong.
- Adam got all the questions right, but took the longest.
- Natalie finished second, but got two questions wrong.
- Gabriella got more questions right than Natalie, but finished after her.
- Kamilla wasn't as fast as Natalie, but Natalie was not as fast as Hailey.

If all the above statements are true, only one of the sentences below **cannot** be true. Which one?

- A Gabriella got fewer questions right than Adam.
- B Hailey was faster than Kamilla.
- C Hailey was not first to finish.
- D Hailey got fewest questions right.

30 An advertisement for stain remover claimed:

STAIN-GONE never fails to remove a stain.

Four stained items of clothing were washed, and two questions were asked in each case:

<i>item</i>	<i>Was STAIN-GONE used in the wash?</i>	<i>Was the stain removed?</i>
1	yes	(a)
2	(b)	yes
3	no	(c)
4	(d)	no

Which **two** of the missing answers **must** be known in order to test the truth of the claim in the advertisement?

- A a and b
- B b and d
- C a and d
- D c and d

- 31 Alana wants to buy 4 books. There are 4 shops that sell the books that she wants. The shops, the prices of the books and any special offers are shown in the following table:

	<i>standard price of a book</i>	<i>special offer</i>
shop A	\$24	buy 2, get a 3rd one for half price
shop B	\$20	none
shop C	\$26	buy 3, get a 4th one free
shop D	\$25	buy 1, get a 2nd one for half price

Alana wants to buy all her books from the same shop and to spend as little as possible.

Which shop should Alana buy her books from?

- A shop A
 - B shop B
 - C shop C
 - D shop D
- 32 It's quite common to hear celebrities and politicians boasting about how little they sleep. They like to create the impression that their success and achievement come from their giving up sleep to work exceptionally long hours. But the truth is that success and sleep go hand in hand. A group of Spanish psychologists have interviewed a wide range of successful people over the last 30 years and have found that most of them credit their achievements to plenty of rest and sleep. Far from being an obstacle to a great life, sleep in fact seems to underpin it!
- Which one of the following statements, if true, most **strengthens** the above argument?
- A Average working hours have increased over the last ten years.
 - B People are as honest when interviewed by the press as when they are interviewed by researchers.
 - C Many people view public figures like celebrities and politicians as role models.
 - D Getting less than seven hours of sleep can reduce people's ability to make good decisions.

33 Brook and Joyce wanted to find out which was the most popular traditional game at their school: Wulijini, Buroinjin, Koolchee or Keentan. They did a survey of all the students at the school, and found the following:

- Everyone who liked Wulijini also liked Koolchee.
- Some people liked both Koolchee and Buroinjin.
- No one liked both Buroinjin and Wulijini.
- There were more people who only liked Koolchee than people who only liked Buroinjin.
- All the Keentan fans were also fans of Wulijini.

Which was the most popular game?

- A** Wulijini
- B** Koolchee
- C** Buroinjin
- D** Keentan

34 150 people were asked to name their favourite type of movie. The results were as follows:

fantasy	66
comedy	42
romance	27
horror	15

No other types of movie were chosen.

The information was entered into a computer in order to construct a pie chart. However, one of the types of movie was missed out. As a result, this was the pie chart that appeared on the screen.

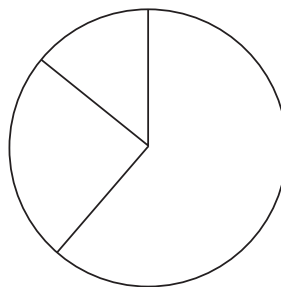

Which type of movie was missed out?

- A** fantasy
- B** comedy
- C** romance
- D** horror

- 35 What is the point in spending time and effort learning things when you can just look them up on the internet? Even doctors these days now find themselves using Google when they want to try to decide what is wrong with a patient. Was it really necessary for them to have spent years studying science and medicine, when the information can now be found online in an instant? As technology progresses, and as more and more people have access to the internet, it surely becomes more and more of a waste of time gaining knowledge. Memorising facts should become a thing of the past.

Which one of these statements, if true, most **weakens** the above argument?

- A Some doctors do not use the internet to assist them with their work.
 - B There is more information on the internet than any one human would be able to memorise.
 - C People need some existing knowledge in order to make sense of information they find online.
 - D In many jobs, practical skills are more valuable than knowing a lot of facts.
- 36 I am hiding in one of three rooms. On the door of each room I have written two statements, some true, some false. However, no more than one statement on each door is false.

<i>Room 1</i>	<i>Room 2</i>	<i>Room 3</i>
My name is Aziz	I am not in this room	My name is Luisa
I am not in this room	I am in Room 3	I am not in Room 1

Which one of the following statements must be true?

- A My name is Aziz.
- B I'm in Room 1.
- C I'm in Room 3.
- D My name is Luisa.

37 Yesterday, in the dog park, I saw 8 dog owners exercising their dogs.
Some of the dog owners had 1 dog, and some dog owners had 2 dogs.
Counting the legs of the dogs and the legs of the dog owners, there was a total of 60 legs.
All dogs have 4 legs and all dog owners have 2 legs.
How many dog owners had only 1 dog?

- A 3
- B 4
- C 5
- D 6

38 There are two ways to qualify for the annual Grant County Athletics Championship: by winning at least three local events during the year, or by breaking a county record.
This year, 10 students from Lisa's school have qualified for the Championship.



Lisa: "I know that a total of six county records were broken by our students this year. So that means that more than half of our qualifiers must be record-breakers!"

Which one of the following sentences shows the mistake Lisa has made?

- A Some of the students from Lisa's school may have broken more than one county record.
- B Some county records may have been broken more than once.
- C The number of county records broken this year may be higher than usual.
- D Some students who broke county records may also have won three local events or more.

39 Muhammad's school wanted to find out how different sports affected people's fitness levels. They made all the best sports people take a fitness test. This is what they found:

- The fittest runners were fitter than the fittest swimmers.
- All the gymnasts were fitter than most of the runners.
- All the swimmers were fitter than all the gymnasts.

Which one of these sentences can be concluded from the above information?

- A** The swimmers' average fitness level was better than those of the other groups.
- B** The range of fitness levels was the greatest amongst the runners.
- C** Runners and swimmers will generally be fitter than gymnasts.
- D** There was less of a range of fitness levels amongst the gymnasts than amongst the swimmers.

40 Three different shapes are shown below.

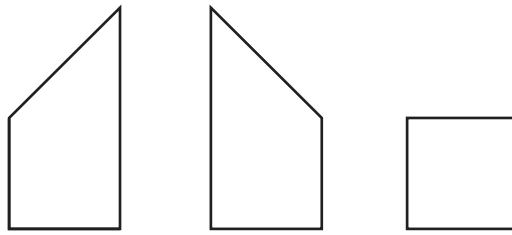

Which one of the following arrangements **cannot** be made by putting these three shapes together?

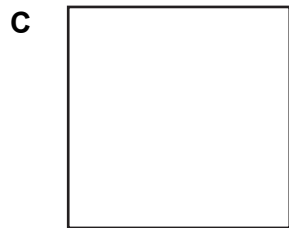
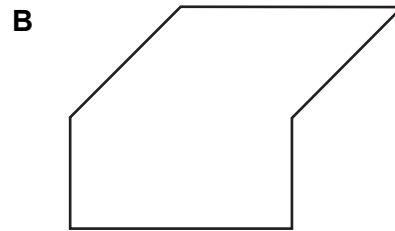
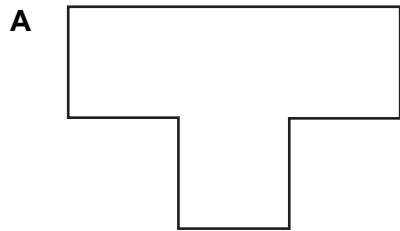

BLANK PAGE



Student application number

S	2	1	0						
---	---	---	---	--	--	--	--	--	--

Given name(s)

Family name

Selective High School Placement Test

Writing Question Paper

Sample Test

30 minutes

INSTRUCTIONS TO CANDIDATES

Please read this page carefully.

DO NOT OPEN THIS QUESTION PAPER UNTIL YOU ARE TOLD TO DO SO.

A separate answer sheet is provided for this test. Please fill in the following information on your answer sheet:

- Student application number
- Given name(s)
- Family name

Please ensure you fill in your student application number on both sides of the answer sheet.

This question paper contains **one** task.

There is space on the question paper for notes. **Your answer must be written on the answer sheet provided.** No additional answer sheets may be used.

The task provides an opportunity for you to show how well you can select, develop and organise ideas and communicate them effectively in writing.

Before you begin writing, take time to think carefully about what you need to say and the ways in which the organisation and layout of your response might help express your message.

You **must** complete your response within **30 minutes**.

Dictionaries and calculators are **NOT** permitted.



Cambridge Assessment
Admissions Testing

PV2

You can use this space and the back page for any planning or notes.

Remember that your answer must be written on the separate answer sheet provided.

- 1 Read the task below and write your answer **on the separate answer sheet.**

New to the area

Three new students have just arrived in your local area. Your teacher has asked you to write an advice sheet for them, making them feel enthusiastic about coming to your school.

Write an advice sheet for the new students about how to get on well in your school and local area.

BLANK PAGE